



I-9602LW-NG Addressable Gas Detector



Installation and Operation Manual

Issue 1.06 January 2014

ERP:30303598

CONTENTS

| | | |
|------|--------------------------|---|
| I | Description..... | 1 |
| II | Connection & Wiring..... | 1 |
| III | Installation | 2 |
| IV | Application | 5 |
| V | Maintenance | 6 |
| VI | Caution | 7 |
| VII | Specification..... | 8 |
| VIII | WEEE Information..... | 9 |
| IX | Limited Warranty | 9 |

I Description

I-9602LW-NG Addressable Gas Detector is used to detect leakage of natural gas in any house or building being the place of residence or home of a household, family or person.

II Connection & Wiring

Terminal of the detector is as in Fig. 1.

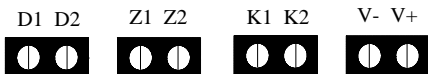

Fig. 1

Terminal description:

D1, D2: Connecting with non-polarized 24VDC power cable.

Z1, Z2: Connecting with loop, non-polarized.

V+, V-: Connecting with pipe solenoid valve. There is a +12V pulse between V+, V- terminals if the detector alarms for 3 to 7 seconds continuously.

K1, K2: 24V/1A normally open voltage-free contact which closes if the detector alarms.

Warning: It's prohibited to drive 220VAC

equipment through K1 and K2.

Recommended Wiring:

The power cable connecting with D1 and D2 shall be 2.5mm² or above flame-retardant copper-core. Cable connecting with Z1 and Z2, V+ and V- and K1 and K2 shall be 1.0mm² or above flame-retardant copper-core.

III Installation

The detector is suitable for the installation that cables are hidden behind it. Please pull out the cables from the electric box through the hole on the center of the base, then install the base onto the electric box and then connect the cables to corresponding terminals according to the terminal mark and this installation and operation manual. And finally install the detector onto the base. Please refer to Fig. 2 for the installation method.

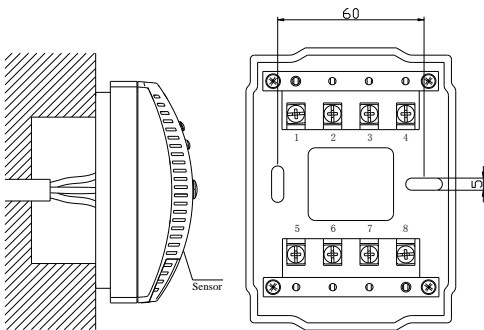

Fig. 2

The detector is wall-mounted (Fig. 3) whose location should be decided according to the type of gas and the position of stove. But there are some general rules to follow:

- ✧ The detector should be placed in the same room with the stove.
- ✧ The vertical distance from the detector to the gas source or stove should be not less than 50cm.
- ✧ The location of the detector to the gas source or stove should be within 1.5 to 4 meters.

To use the detector correctly and avoid any possible trouble, please do not mount the detector at the following locations:

- ✧ Where affected by smoke or vapor from the stove.
- ✧ Where near strong airflow, such as air-inlets, fans, doors, etc.
- ✧ Where near bathroom or places with a lot of vapor.
- ✧ Rooms for boiling water and places where power is cut at night.
- ✧ Where temperature is below -10°C or over 50°C or outdoors.
- ✧ Where explosion-proof measures are required.
- ✧ Where the detector is partitioned with the gas devices.

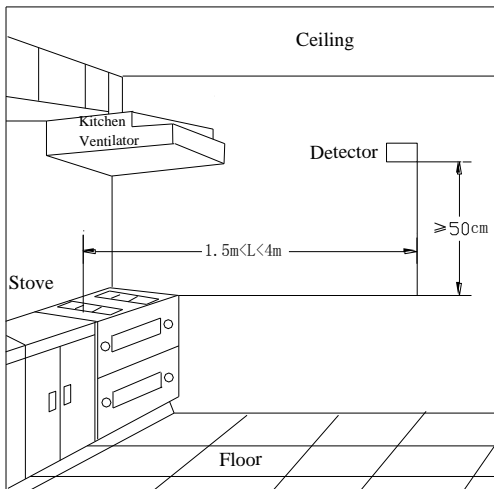

Fig. 3

IV Application

- 1 Applying power supply to the detector after wiring and checking, the green LED will flash for 3 to 6 minutes for warm-up, and then it will

- illuminate steadily to indicate the detector has entered normal standby status.
- 2 If the detector alarms, the *Alarm/Fault* LED flashes red, and the buzzer sounds about twice every second. If the detector is in trouble, the *Alarm/Fault* LED illuminates yellow steadily, and the buzzer sounds once every 3 seconds.
 - 3 There is a *Self Test* button on the detector to test if the LEDs and buzzer works normally. Pressing the *Self Test* button, the LEDs flash once in turns, and the buzzer sounds three times.

V Maintenance

- 1 The detector should be tested every 6 months. It's allowed to use a gas cigarette lighter to test the detector. Put the lighter near the sensor (over 10cm) press its switch to turn it on and then blow off the flame. The detector should alarm in about 10 seconds.
- 2 Please replace the sensor every 5 years.
- 3 The detector will normally be a bit hot in operation.

VI Caution

- 1 Each type of detector can only detect the kind of gas nominated on its label.**
- 2 Don't install the detector at locations with high temperature (near stoves) or too much smoke (near kitchen ventilator); Keep environment around the detector clean.**
- 3 The detector can only work with the JJ or FCR series solenoid coming with the detector. If other models are to be used, please consult us.**
- 4 Never cut down the power of the detector.**
- 5 After having been stored without power, the detector will not work normally until it is powered for a period.**

VII Specification

| | |
|----------------------------------|--------------------------------|
| Power Voltage | 24VDC |
| Loop Voltage | Loop 24V |
| Normal Standby Power Consumption | ≤0.5W |
| Alarm Power Consumption | ≤3W |
| Type of Gas | Natural gas |
| Alarm Threshold | 6%LEL(methane) |
| Life of the Sensor | 5 years |
| Ingress Protection | IP30 |
| Temperature | -10°C ~ +50°C |
| Relative Humidity | ≤95%, non-condensing |
| Material and Color | ABS, ivory white |
| Weight | 180g (with base) |
| Dimension (L×W×H) | 121mm×87mm×57mm (with base) |
| Mounting Hole Spacing | 60mm |

VIII WEEE Information



2012/19/EU (WEEE directive): Products marked with this symbol cannot be disposed of as unsorted municipal waste in the European Union. For proper recycling, return this product to your local supplier upon the purchase of equivalent new equipment, or dispose of it at designated collection points.

IX Limited Warranty

GST warrants that the product will be free from defects in design, materials and workmanship during the warranty period. This warranty shall not apply to any product that is found to have been improperly installed or used in any way not in accordance with the instructions supplied with the product. Anybody, including the agents, distributors or employees, is not in the position to amend the contents of this warranty. Please contact your local distributor for products not covered by this warranty.



Gulf Security Technology Co., Ltd.

No. 80, Changjiang East Road, QETDZ, Qinhuangdao, Hebei,
P. R. China 066004

Tel: +86 (0) 335 8502434

Fax: +86 (0) 335 8502532

service@fs.utc.com

www.gst.com.cn